

環保新冷媒

R407C



HITACHI
Inspire the Next

HITACHI PACKAGED AIR CONDITIONERS WATER-COOLED TYPE

日立水冷式箱型空調機

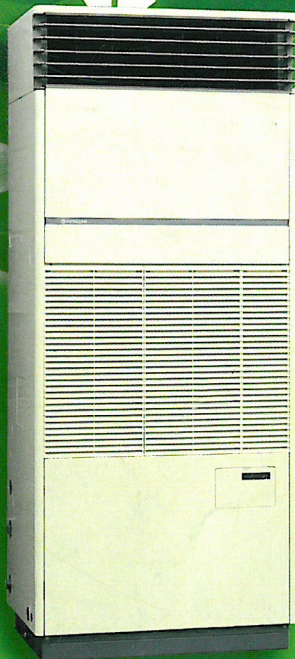

Models :

Free-Blow Type
直吹型

RP-P5W
RP-P8W
RP-P10W
RP-P15W

Duct-Connection Type
風管型

RP-P5WP
RP-P8WP
RP-P10WP
RP-P15WP
RP-P20WP
RP-P25WP
RP-P30WP
RP-P40WP

Nominal Capacity Range
額定容量範圍

12,000 kcal/h to 96,300 kcal/h	at 50Hz
14,000 W to 112,000 W	at 50Hz
47,700 Btu/h to 382,100 Btu/h	at 50Hz
13,800 kcal/h to 107,500 kcal/h	at 60Hz
16,000 W to 125,000 W	at 60Hz
54,600 Btu/h to 426,500 Btu/h	at 60Hz

STREAM LINED SHAPE AND TOP OF THE LINE PERFORMANCE PERFECTED WITH A HIGH-EFFICIENCY COMPONENTS

HITACHI has developed packaged air conditioners <water-cooled type> with a sleek new look. In addition to excellent performance providing high efficiency, high reliability and low noise, the design has been upgraded. Moreover, a slim design has further relaxed restrictions on installation. The air conditioners of this type are available for use in factories, shopping center, offices, restaurants, karaoke bars, super markets and similar places. An extensive lineup features 5 to 40 horsepower models. All horsepower models adopt a high efficiency scroll compressor. Users can choose the optimum model according to applications or purposes.

日立水冷式箱型空調機，除了具有流線型美觀的設計外，它優越的品質更是備受肯定，為了提升產品性能，在設計上更要求高效率、低噪音及高信賴度。除此之外，更精巧地減少安裝空間的限制，無論是工廠、購物中心、辦公室、餐廳、卡拉OK俱樂部或超級市場等類似場所均適用。日立水冷式箱型的機型包括5~40匹馬力，全系列的機型都採用了渦卷式壓縮機，顧客可依自己的需求選擇最適合的機型，搭配使用。

FEATURES 特點

- ◆ Adopting R407C refrigerant.
採用環保新冷媒R407C
- ◆ Slim design, space saving, energy saving.
流線型設計、省空間、省能源
- ◆ Low noise, low vibration.
低噪音、低振動
- ◆ Easy Operation.
操作簡單
Electrical control, easy operation and failure check.
運轉控制電子化，操作與檢點容易。
- ◆ Completely control and protection function.
完整控制及保護功能
 - (1) Compressor protection design
(To avoid compressor damaged by sudden power ON/OFF).
壓縮機運轉保護功能。
 - (2) Remote wiring control of temperature adjustment (For special order).
可利用信號接點連接室內溫度調節開關（特別受注）。
 - (3) Quick restart (Within 2 seconds).
瞬間停電後自動復電（2秒以內）。
 - (4) Anti frost function (Cooler Assembly side).
防止蒸發器結霜控制功能。

OPTIONAL PARTS 選購配件

- ◆ Electric heater, Hot water heater, Steam heater
電氣加熱器、溫水加熱器、蒸氣加熱器
- ◆ Humidifier
加濕器
- ◆ Long life air filter
長壽命空氣濾網



DIMENSION 外觀尺寸

FREE-BLOW TYPE (直吹型)

RP-P5W

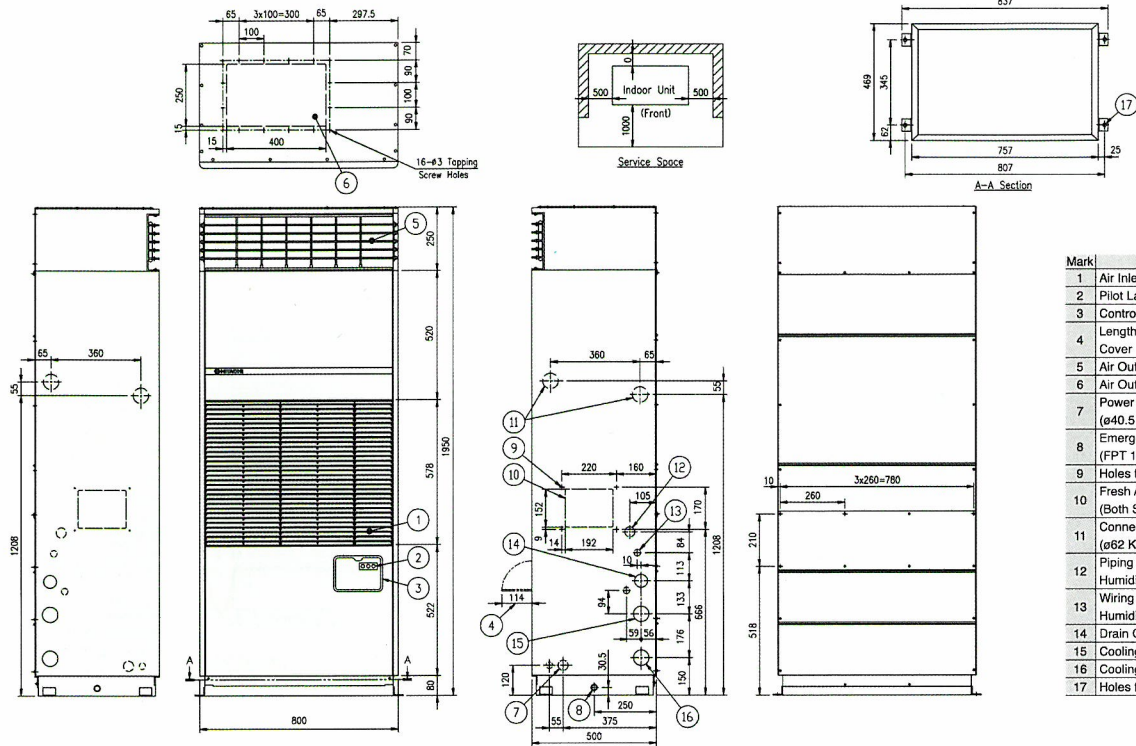

Mark	Name
1	Air Inlet (Front)
2	Pilot Lamp
3	Control Panel Cover
4	Length for Opening Control Panel Cover
5	Air Outlet (Front)
6	Air Outlet (Upper)
7	Power Source Wiring Hole (ø40.5 Knockout Hole)
8	Emergency Drain Connection (FPT 1/2")
9	Holes for Tapping Screw
10	Fresh Air Inlet (Both Sides by Duct, Field Option)
11	Connection Hole for Optional Heater (ø62 Knockout Hole)
12	Piping Connection Hole for Optional Humidifier (ø40.5 Knockout Hole)
13	Wiring Connection Hole for Optional Humidifier (ø26.1 Knockout Hole)
14	Drain Connection (FPT 1")
15	Cooling Water Outlet (FPT 1-1/4")
16	Cooling Water Inlet (FPT 1-1/4")
17	Holes for Anchor Bolt (4-M8)

RP-P8W

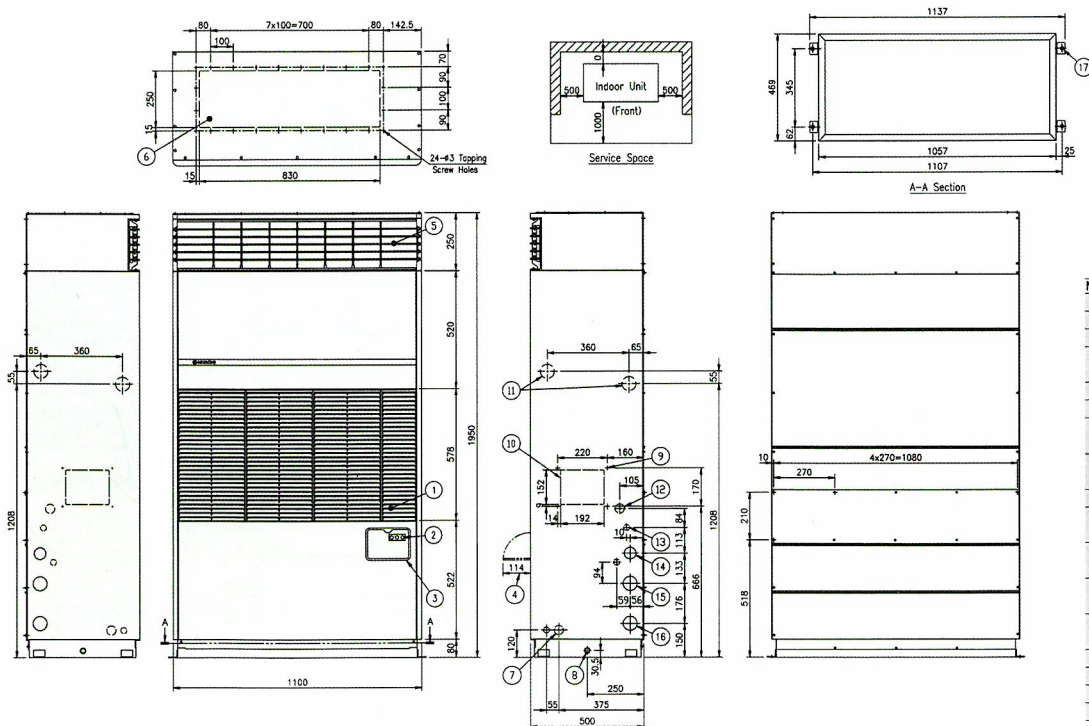

Mark	Name
1	Air Inlet (Front)
2	Pilot Lamp
3	Control Panel Cover
4	Length for Opening Control Panel Cover
5	Air Outlet (Front)
6	Air Outlet (Upper, for Branch Duct)
7	Power Source Wiring Hole (ø40.5 Knockout Hole)
8	Emergency Drain Connection (FPT 1/2")
9	Holes for Tapping Screw
10	Fresh Air Inlet (Both Sides by Duct, Field Option)
11	Connection Hole for Optional Heater (ø62 Knockout Hole)
12	Piping Connection Hole for Optional Humidifier (ø40.5 Knockout Hole)
13	Wiring Connection Hole for Optional Humidifier (ø26.1 Knockout Hole)
14	Drain Connection (FPT 1")
15	Cooling Water Outlet (FPT 1-1/2")
16	Cooling Water Inlet (FPT 1-1/2")
17	Holes for Anchor Bolt (4-M8)

DIMENSION 外觀尺寸

FREE-BLOW TYPE (直吹型)

RP-P10W

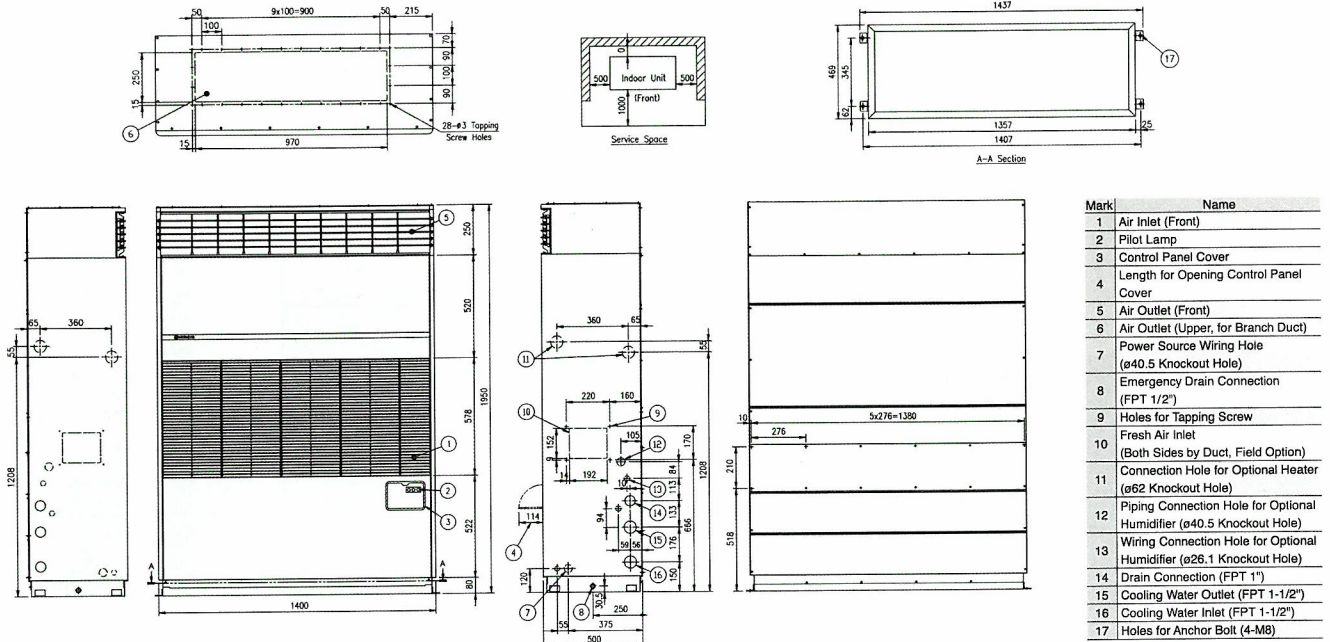

RP-P15W

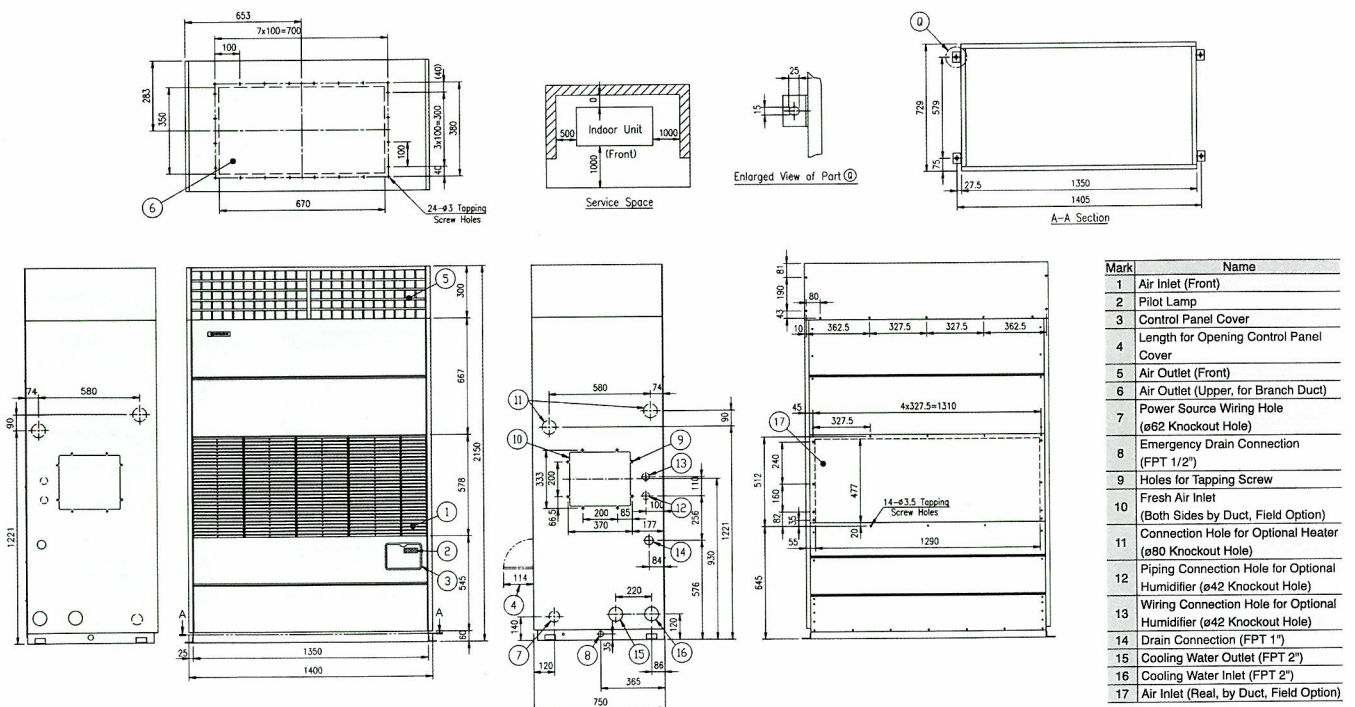

DUCT-CONNECTION TYPE (風管型)

RP-P5WP

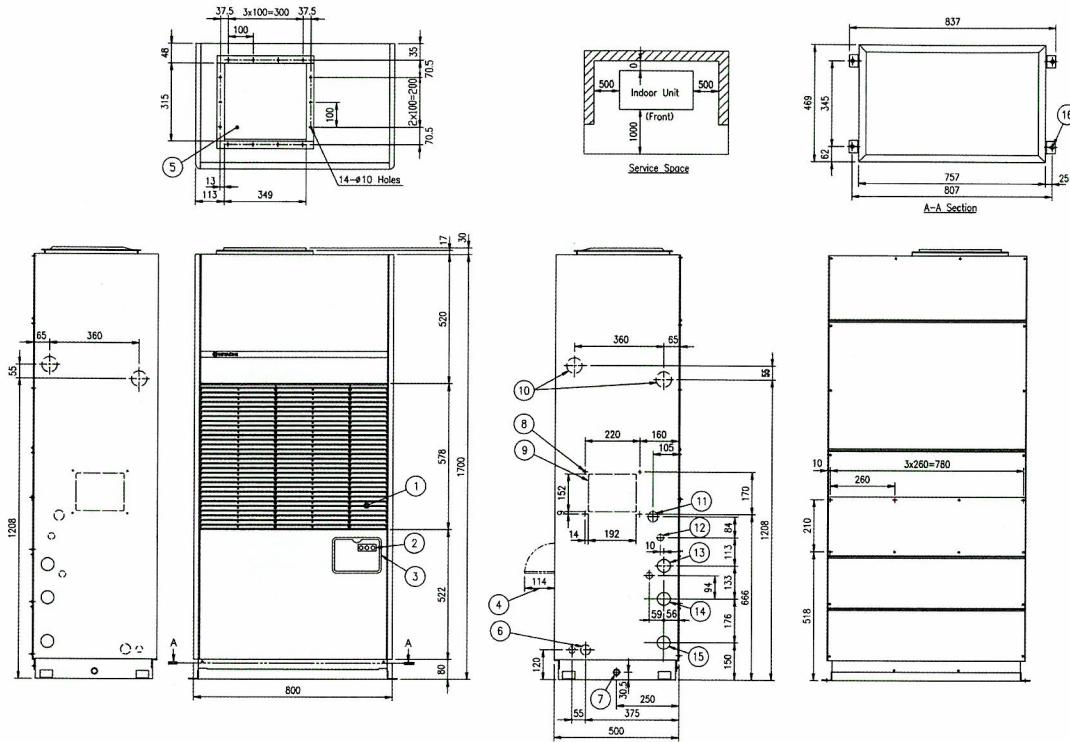

Mark	Name
1	Air Inlet (Front)
2	Pilot Lamp
3	Control Panel Cover
4	Length for Opening Control Panel Cover
5	Air Outlet
6	Power Source Wiring Hole (ø40.5 Knockout Hole)
7	Emergency Drain Connection (FPT 1/2")
8	Holes for Tapping Screw
9	Fresh Air Inlet (Both Sides by Duct, Field Option)
10	Connection Hole for Optional Heater (ø82 Knockout Hole)
11	Piping Connection Hole for Optional Humidifier (ø40.5 Knockout Hole)
12	Wiring Connection Hole for Optional Humidifier (ø26.1 Knockout Hole)
13	Drain Connection (FPT 1")
14	Cooling Water Outlet (FPT 1-1/4")
15	Cooling Water Inlet (FPT 1-1/4")
16	Holes for Anchor Bolt (4-M8)

RP-P8WP

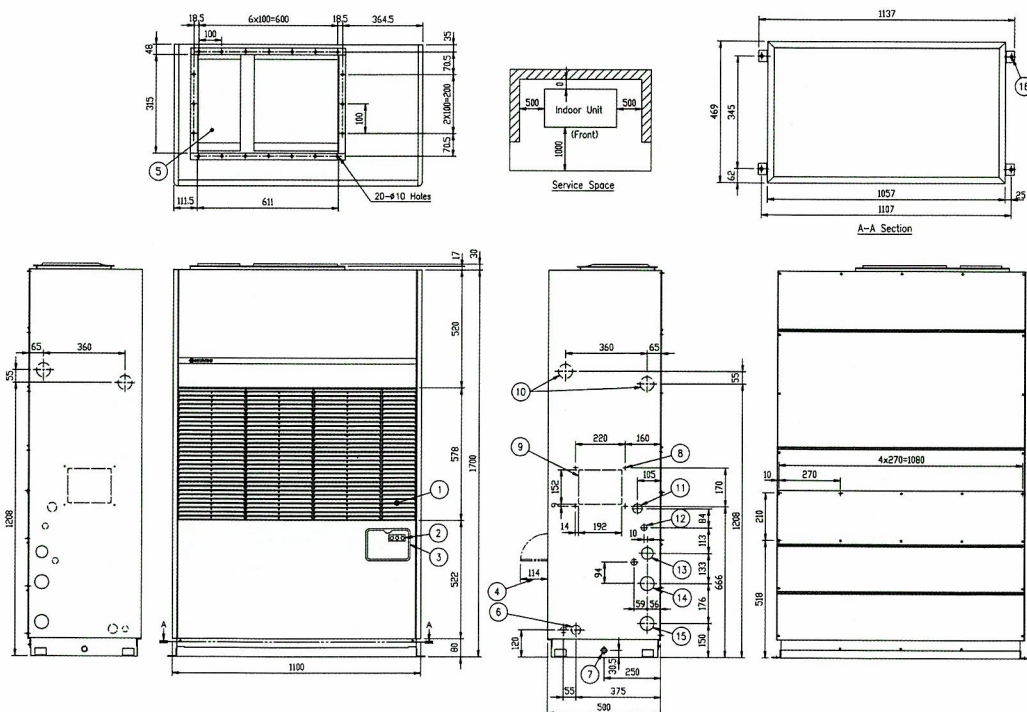

Mark	Name
1	Air Inlet (Front)
2	Pilot Lamp
3	Control Panel Cover
4	Length for Opening Control Panel Cover
5	Air Outlet
6	Power Source Wiring Hole (ø40.5 Knockout Hole)
7	Emergency Drain Connection (FPT 1/2")
8	Holes for Tapping Screw
9	Fresh Air Inlet (Both Sides by Duct, Field Option)
10	Connection Hole for Optional Heater (ø82 Knockout Hole)
11	Piping Connection Hole for Optional Humidifier (ø40.5 Knockout Hole)
12	Wiring Connection Hole for Optional Humidifier (ø26.1 Knockout Hole)
13	Drain Connection (FPT 1")
14	Cooling Water Outlet (FPT 1-1/2")
15	Cooling Water Inlet (FPT 1-1/2")
16	Holes for Anchor Bolt (4-M8)

DIMENSION 外觀尺寸

DUCT-CONNECTION TYPE (風管型)

RP-P10WP

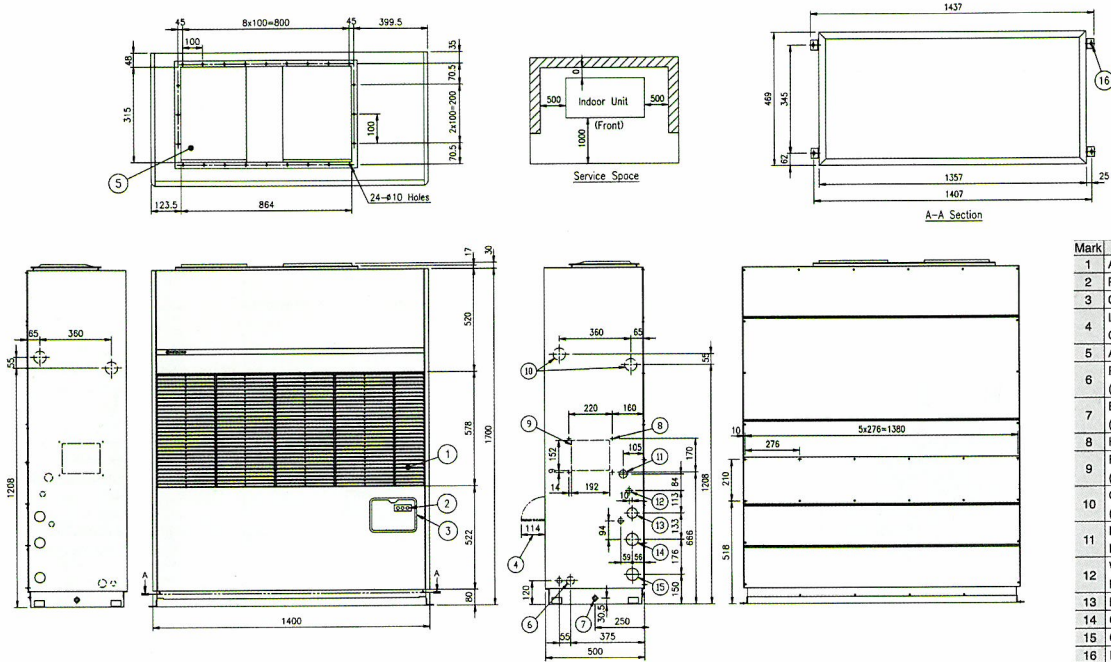

Mark	Name
1	Air Inlet (Front)
2	Pilot Lamp
3	Control Panel Cover
4	Length for Opening Control Panel Cover
5	Air Outlet
6	Power Source Wiring Hole (ø40.5 Knockout Hole)
7	Emergency Drain Connection (FPT 1/2")
8	Holes for Tapping Screw
9	Fresh Air Inlet (Both Sides by Duct, Field Option)
10	Connection Hole for Optional Heater (ø62 Knockout Hole)
11	Piping Connection Hole for Optional Humidifier (ø40.5 Knockout Hole)
12	Wiring Connection Hole for Optional Humidifier (ø26.1 Knockout Hole)
13	Drain Connection (FPT 1")
14	Cooling Water Outlet (FPT 1-1/2")
15	Cooling Water Inlet (FPT 1-1/2")
16	Holes for Anchor Bolt (4-M8)

RP-P15WP

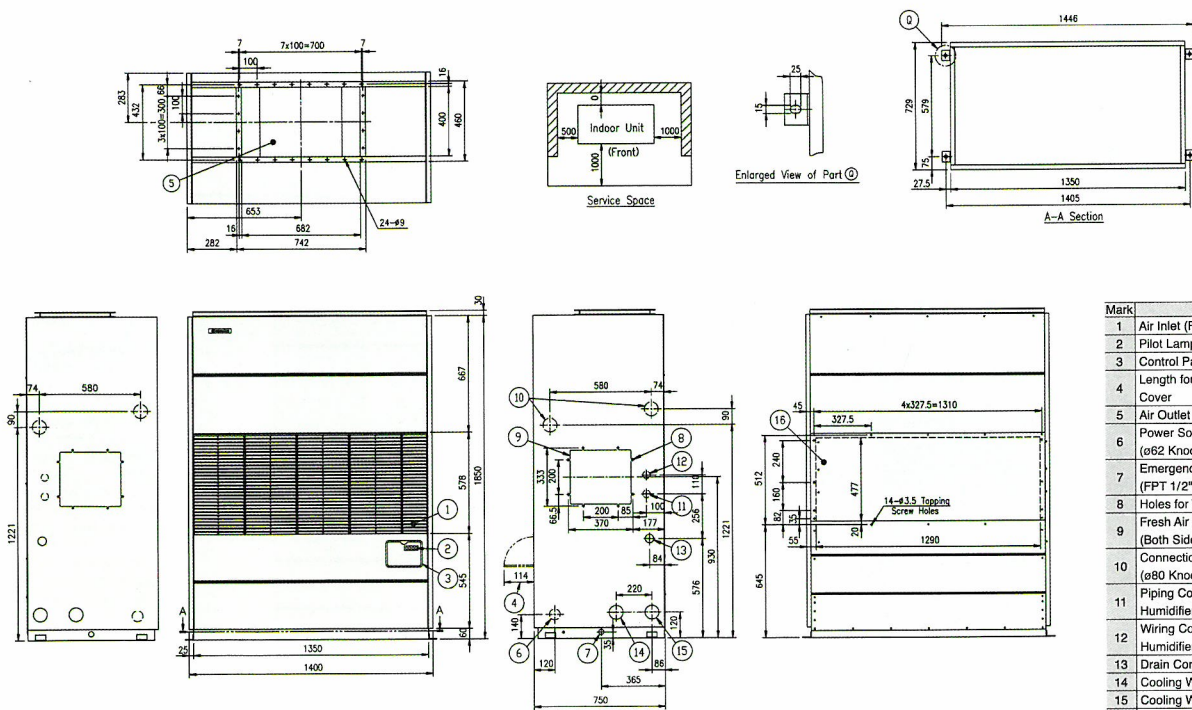

Mark	Name
1	Air Inlet (Front)
2	Pilot Lamp
3	Control Panel Cover
4	Length for Opening Control Panel Cover
5	Air Outlet (Upper, by Duct)
6	Power Source Wiring Hole (ø62 Knockout Hole)
7	Emergency Drain Connection (FPT 1/2")
8	Holes for Tapping Screw
9	Fresh Air Inlet (Both Sides by Duct, Field Option)
10	Connection Hole for Optional Heater (ø80 Knockout Hole)
11	Piping Connection Hole for Optional Humidifier (ø42 Knockout Hole)
12	Wiring Connection Hole for Optional Humidifier (ø42 Knockout Hole)
13	Drain Connection (FPT 1")
14	Cooling Water Outlet (FPT 2")
15	Cooling Water Inlet (FPT 2")
16	Air Inlet (Rear, by Duct, Field Option)

DUCT-CONNECTION TYPE (風管型)

RP-P20WP

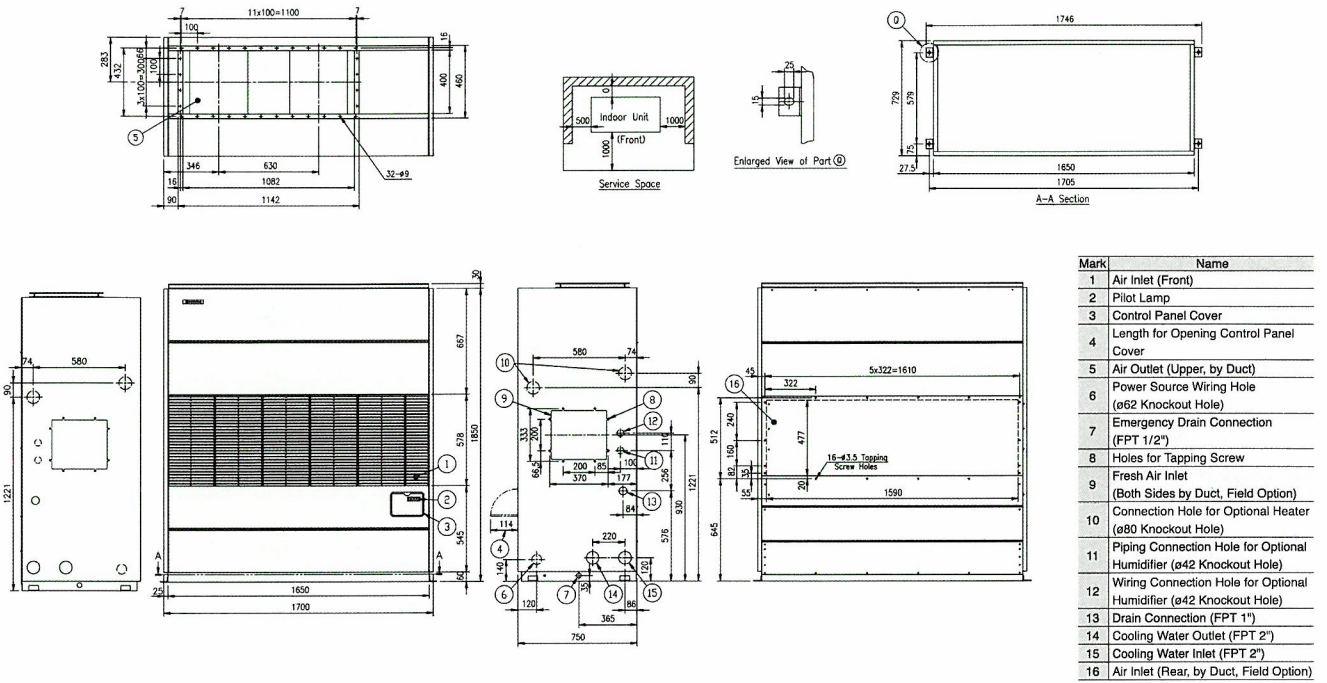

RP-P25WP

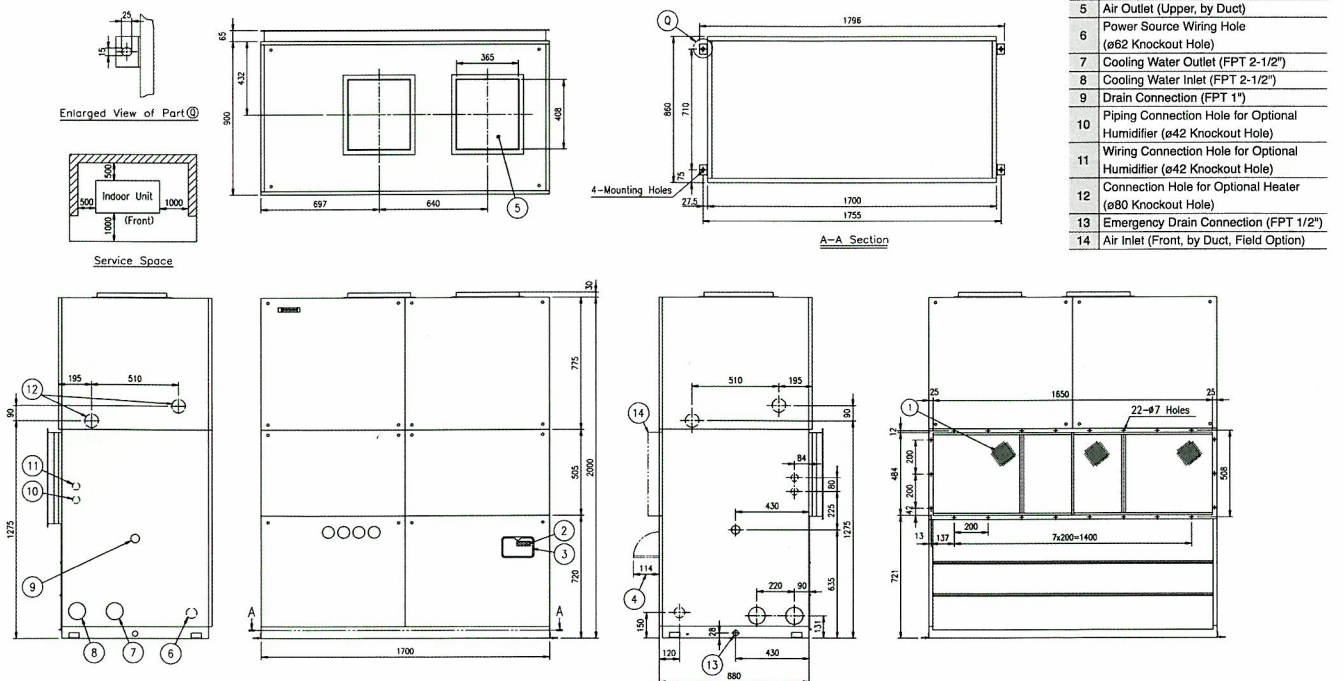

DUCT-CONNECTION TYPE (風管型)

RP-P30WP

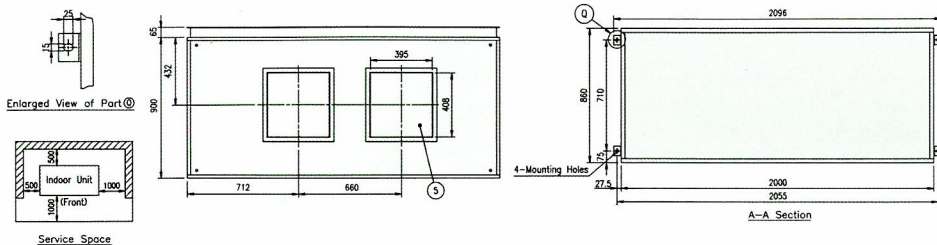

Mark	Name
1	Air Inlet (Rear, by Duct)
2	Pilot Lamp
3	Control Panel Cover
4	Length for Opening Control Panel Cover
5	Air Outlet (Upper, by Duct)
6	Power Source Wiring Hole (ø62 Knockout Hole)
7	Cooling Water Outlet (FPT 2-1/2")
8	Cooling Water Inlet (FPT 2-1/2")
9	Drain Connection (FPT 1")
10	Piping Connection Hole for Optional Humidifier (ø42 Knockout Hole)
11	Wiring Connection Hole for Optional Humidifier (ø42 Knockout Hole)
12	Connection Hole for Optional Heater (ø80 Knockout Hole)
13	Emergency Drain Connection (FPT 1/2")
14	Air Inlet (Front, by Duct, Field Option)

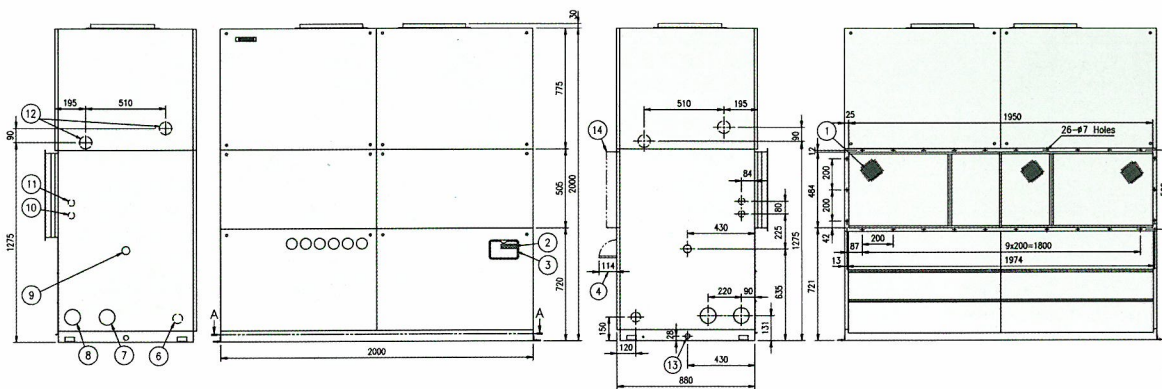

RP-P40WP

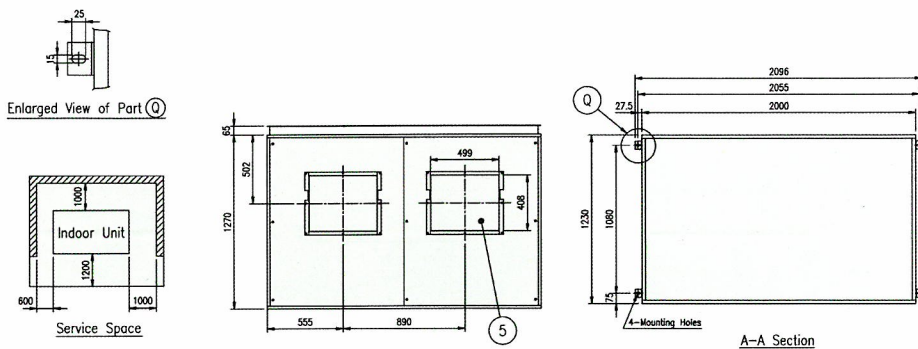

Mark	Name
1	Air Inlet
2	Pilot Lamp
3	Control Panel Cover
4	Length for Opening Control Panel Cover
5	Air Outlet (Upper, by Duct)
6	Power Source Wiring Hole (ø80 Knockout Hole)
7	Cooling Water Outlet (FPT 2-1/2")
8	Cooling Water Inlet (FPT 2-1/2")
9	Drain Connection (FPT 1")
10	Piping Connection Hole for Optional Humidifier (ø42 Knockout Hole)
11	Wiring Connection Hole for Optional Humidifier (ø42 Knockout Hole)
12	Connection Hole for Optional Heater (ø80 Knockout Hole)
13	Emergency Drain Connection (FPT 1/2")
14	Connection Hole for Refrigerant Exhaust from Fusible Plug (ø42 Knockout Hole)

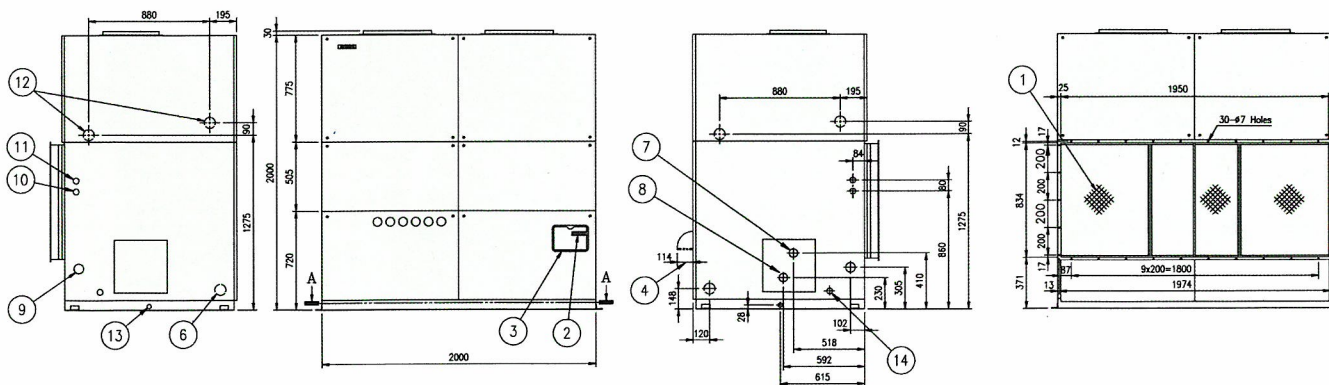

GENERAL DATA 一般規格

FREE-BLOW TYPE (直吹型)

Item (unit)			Model	RP-P5W	RP-P8W	RP-P10W	RP-P15W		
Nominal Cooling Capacity*	50Hz	kcal/h		12,000	19,300	24,100	38,700		
		W		14,000	22,400	28,000	45,000		
	60Hz	Btu/h		47,700	76,400	95,500	153,600		
		kcal/h		13,800	21,500	27,100	43,000		
		W		16,000	25,000	31,500	50,000		
		Btu/h		54,600	85,300	107,500	170,600		
Capacity Control		%		100.0	100.0	100.0	100.63,0		
Cabinet Color			Synthetic Resin Paint Baked on Finished Steel Plates						
Front Panel, Side Panel (MUNSELL Code)				Beige (2.5Y 8/2)	Beige (2.5Y 8/2)	Beige (2.5Y 8/2)	Beige (2.5Y 8/2)		
Air Outlet Grill (MUNSELL Code)				Gray (2.5Y 4.5/0.7)	Gray (2.5Y 4.5/0.7)	Gray (2.5Y 4.5/0.7)	Beige (2.5Y 8/2)		
Outer Dimensions	Height	mm		1,950	1,950	1,950	2,150		
		(in.)		(76-3/4)	(76-3/4)	(76-3/4)	(84-11/16)		
	Width	mm		800	1,100	1,400	1,400		
		(in.)		(31-1/2)	(43-5/16)	(55-1/8)	(55-1/8)		
Depth	mm		500	500	500	750			
	(in.)		(19-11/16)	(19-11/16)	(19-11/16)	(29-1/2)			
Net Weight		kg		170	285	320	495		
		(lbs.)		(375)	(628)	(705)	(1,091)		
Refrigerant**				R407C	R407C	R407C	R407C		
Flow Control				CPT	CPT	CPT	CPT		
Number of Circuits				1	1	1	2		
Compressor Type				Hermetic Scroll	Hermetic Scroll	Hermetic Scroll	Hermetic Scroll		
Quantity				1	1	1	1+1		
Evaporator				Multi-Pass Cross-Finned Tube					
Condenser				Coiled Double Tube					
Evaporator Fan				Multi-Blade Centrifugal Fan					
Nominal Air Flow (Hi/Lo)	m ³ /min			44/38	66	88	130		
		m ³ /s		0.73/0.63	1.1	1.47	2.17		
		L/s		733/633	1,100	1,467	2,167		
		(cfm)		(1,554/1,342)	(2,330)	(3,108)	(4,590)		
Motor	kW			0.13	0.25	0.30	1.5		
	(HP)			(0.17)	(0.33)	(0.40)	(2)		
Quantity				1	1	1	1		
Condenser Water Quantity (50/60Hz)			m ³ /h	3.1/3.5	At the Condenser Water Inlet Temperature 30°C 4.9/5.5		6.2/7.0	10.0/11.2	
Connections				Female Piping Thread Screw (Prepared on Both Sides)					
Condenser Water Size	Inlet	FPT		1-1/4	1-1/2	1-1/2	2		
		FPT		1-1/4	1-1/2	1-1/2	2		
Condensate Drain Size	FPT			1	1	1	1		
				1	1	1	1		
Emergency Drain Size	FPT			1/2	1/2	1/2	1/2		
				1/2	1/2	1/2	1/2		
Wiring Hole Size	mm			40.5	40.5	40.5	62		
		(in.)		(1-5/8)	(1-5/8)	(1-5/8)	(2-7/16)		
Approximate Packing List							Unit	Plenum Chamber	
Shipping Weight	kg			215	355	380	520	40	
		(lbs.)		(474)	(739)	(838)	(1,146)	(88)	
Height	mm			2,125	2,125	2,125	2,070	460	
		(in.)		(83-5/8)	(83-5/8)	(83-5/8)	(81-1/2)	(18-1/8)	
Width	mm			914	1,214	1,514	1,510	1,480	
		(in.)		(36)	(47-13/16)	(59-5/8)	(59-7/16)	(58-9/32)	
Depth	mm			628	628	628	880	850	
		(in.)		(24-3/4)	(24-3/4)	(24-3/4)	(34-5/8)	(33-13/32)	
Measurements		m ³		1.22	1.62	2.02	2.75	0.58	

CPT : Capillary Tube

Notes:

- * The nominal cooling capacity is based on the standard of JIS B8616-1999
 Evaporator Air Inlet Temperature: 27°C DB (80.6°F DB)
 19°C WB (66.2°F WB)
 Condenser Water Inlet Temperature: 30°C (86°F)
 Condenser Water Outlet Temperature: 35°C (95°F)
- ** Factory-Charged

Working Range:

- Evaporator Air Inlet Temperature at Standard Air Flow :
- Maximum : 32°C DB/23°C WB (89.6°F DB/73.4°F WB)
 - Minimum : 21°C DB/15°C WB (69.8°F DB/59.0°F WB)
- Condenser Water Outlet Temperature:
- Maximum : 38°C (100.4°F)
 - Minimum : 21°C (69.8°F)

Standard Power Supply

Main (3φ)		Control (1φ)	
220V	60Hz	220V	60Hz
220V	50Hz	220V	50Hz
380V	50Hz	220V	50Hz
415V	50Hz	240V	50Hz

GENERAL DATA 一般規格

DUCT-CONNECTION TYPE (風管型)

Item (unit)			Model	RP-P5WP	RP-P8WP	RP-P10WP	RP-P15WP	RP-P20WP	RP-P25WP	RP-P30WP	RP-P40WP
Nominal Cooling Capacity*	50Hz	kcal/h		12,000	19,300	24,100	38,700	48,100	61,000	77,400	96,300
		W		14,000	22,400	28,000	45,000	56,000	71,000	90,000	112,000
	60Hz	Btu/h		47,700	76,400	95,500	153,600	191,100	242,200	307,100	382,100
		kcal/h		13,800	21,500	27,100	43,000	54,200	68,800	86,000	107,500
		W		16,000	25,000	31,500	50,000	63,000	80,000	100,000	125,000
		Btu/h		54,600	85,300	107,500	170,600	214,900	272,900	341,200	426,500
Capacity Control		%		100,0	100,0	100,0	100,63,0	100,50,0	100,50,0	100,67,33,0	100,67,33,0
Cabinet Color				Synthetic Resin Paint Baked on Finished Steel Plates							
Front Panel, Side Panel (MUNSELL Code)				Beige (2.5Y 8/2)	Beige (2.5Y 8/2)	Beige (2.5Y 8/2)	Beige (2.5Y 8/2)	Beige (2.5Y 8/2)	Beige (2.5Y 8/2)	Beige (2.5Y 8/2)	Beige (2.5Y 8/2)
Air Outlet Grill (MUNSELL Code)				—	—	—	—	—	—	—	—
Outer Dimensions	Height	mm		1,730	1,730	1,730	1,850+30	1,850+30	2,000+30	2,000+30	2,000+30
		(in.)		(68-1/8)	(68-1/8)	(68-1/8)	(72-13/16+1-3/16)	(72-13/16+1-3/16)	(78-3/4+1-3/16)	(78-3/4+1-3/16)	(78-3/4+1-3/16)
	Width	mm		800	1,100	1,400	1,400	1,700	1,700	2,000	2,000
		(in.)		(31-1/2)	(43-5/16)	(55-1/8)	(55-1/8)	(66-15/16)	(66-15/16)	(78-3/4)	(78-3/4)
Depth	mm		500	500	500	750	750	900+65	900+65	900+65	1,270+65
	(in.)		(19-11/16)	(19-11/16)	(19-11/16)	(29-1/2)	(29-1/2)	(35-7/16+2-9/16)	(35-7/16+2-9/16)	(35-7/16+2-9/16)	(50+2-9/16)
Net Weight		kg (lbs.)		165 (364)	275 (606)	305 (672)	480 (1,058)	620 (1,367)	710 (1,565)	900 (1,984)	1200 (2,646)
Refrigerant**				R407C	R407C	R407C	R407C	R407C	R407C	R407C	R407C
Flow Control				CPT	CPT	CPT	CPT	CPT	CPT	CPT	CPT
Number of Circuits				1	1	1	2	2	2	3	3
Compressor Type				Hermetic Scroll	Hermetic Scroll	Hermetic Scroll	Hermetic Scroll	Hermetic Scroll	Hermetic Scroll	Hermetic Scroll	Hermetic Scroll
Quantity				1	1	1	1+1	2	2	3	3
Evaporator				Multi-Pass Cross-Finned Tube							
Condenser				Coiled Double Tube							
				Shell-and-Tube Type							
Evaporator Fan				Multi-Blade Centrifugal Fan							
Nominal Air Flow		m ³ /min		44	66	88	130	180	220	260	360
		m ³ /s		0.73	1.1	1.47	2.17	3.00	3.67	4.33	6.0
		L/s		733	1,100	1,467	2,167	3,000	3,667	4,333	6,000
Motor		(cfm)		(1,554)	(2,330)	(3,108)	(4,590)	(6,360)	(7,770)	(9,180)	(12,700)
		kW		0.55	0.75	1.5	2.2	3.7	3.7	5.5	7.5
		(HP)		(0.74)	(1)	(2)	(3)	(5)	(5)	(7.5)	(10)
Quantity				1	1	1	1	1	1	1	1
Condenser Water Quantity (50/60Hz)		m ³ /h		3.1/3.5	4.9/5.5	6.2/7.0	10.0/11.2	12.6/14.2	16.0/18.1	20.2/22.5	24.8/28.1
Connections				Female Piping Thread Screw (Prepared on Both Sides)							
Condenser Water Size	Inlet	FPT		1-1/4	1-1/2	1-1/2	2	2	2-1/2	2-1/2	2-1/2
	Outlet	FPT		1-1/4	1-1/2	1-1/2	2	2	2-1/2	2-1/2	2-1/2
Condensate Drain Size		FPT		1	1	1	1	1	1	1	1
Emergency Drain Size		FPT		1/2	1/2	1/2	1/2	1/2	1/2	1/2	1/2
Wiring Hole Size		mm (in.)		40.5 (1-5/8)	40.5 (1-5/8)	40.5 (1-5/8)	62 (2-7/16)	62 (2-7/16)	62 (2-7/16)	62 (2-7/16)	80 (3-5/32)
Approximate Packing List Shipping Weight		kg (lbs.)		210 (463)	315 (694)	360 (794)	525 (1,157)	705 (1,554)	820 (1,808)	1,020 (2,249)	1,290 (2,844)
Height		mm (in.)		1,905 (75)	1,905 (75)	1,905 (75)	2,070 (81-1/2)	2,070 (81-1/2)	2,225 (87-5/8)	2,225 (87-5/8)	2,225 (87-5/8)
Width		mm (in.)		914 (36)	1,214 (47-13/16)	1,514 (59-5/8)	1,510 (59-7/16)	1,810 (71-1/4)	1,860 (73-1/4)	2,160 (85-1/16)	2,160 (85-1/16)
		mm (in.)		628 (24-3/4)	628 (24-3/4)	628 (24-3/4)	880 (34-5/8)	880 (34-5/8)	1,105 (43-1/2)	1,105 (43-1/2)	1,475 (58-1/16)
Measurements		m ³		1.09	1.45	1.81	2.75	3.30	4.57	5.31	7.09

CPT: 毛細管

註記:

- * 額定冷氣能力是依據 JIS B8616-1999 規格冷氣條件:
 蒸發器吸入空氣溫度: 27°CDB (80.6°FDB)
 19°CWB (66.2°FWB)
 冷凝器冷卻水入口溫度: 30°C (86°F)
 冷凝器冷卻水出口溫度: 35°C (95°F)

標準電源

主回路 (3φ)	操作回路 (1φ)
220V 60Hz	220V 60Hz
220V 50Hz	220V 50Hz
380V 50Hz	220V 50Hz
415V 50Hz	240V 50Hz

- ** 工廠充填

運轉範圍:

- 蒸發器吸入空氣溫度 (標準風量時):
 最高: 32°CDB / 23°CWB (89.6°FDB / 73.4°FWB)
 最低: 21°CDB / 15°CWB (69.8°FDB / 59.0°FWB)
 冷凝器冷卻水出口溫度:
 最高: 38°C (100.4°F)
 最低: 21°C (69.8°F)

Specifications in this catalog are subject to change without notice, in order that HITACHI may bring the latest innovations to our customers.

本說明的內容隨時更改, 恕不另行通知: 此舉有助日立公司隨時把最新的科技創意帶來給客戶採用。